



# INSTRUCTION BULLETIN

No. 9007877  
Machine: S20  
Published: 12-2014  
Rev. 01

**NOTE: DO NOT DISCARD the Parts List from the Instruction Bulletin. Place the Parts List in the appropriate place in the machine manual for future reference. Retaining the Parts List will make it easier to reorder individual parts and will save the cost of ordering an entire kit.**

*NOTE: Numbers in parenthesis ( ) are reference numbers for parts listed in Bill of Materials.*

Installation instructions for **kit number 9007869**

## SYNOPSIS:

This kit contains the parts needed to install a backup alarm / strobe light kit on S20 machines (machines serial numbers 001319 and above only)  
Please follow step-by-step instructions.

## SPECIAL TOOLS / CONSIDERATIONS: NONE

(Estimated time to complete: 1.5 hours)



### PROTECT THE ENVIRONMENT

Please dispose of packaging materials, used machine components such as batteries and fluids in an environmentally safe way according to local waste disposal regulations.

Always remember to recycle.

## PREPARATION:

1. Park the machine on a clean level surface, turn off the machine, remove the key, and set the parking brake.

**FOR SAFETY: Before leaving or servicing machine, stop on level surface, turn off machine, and remove key.**

2. Disconnect the battery cables from the battery.



**WARNING: Always disconnect battery cables from machine before working on electrical components.**

3. Check the rear engine mounting bracket. If rear engine mounting bracket has a location for installing the reverse switch bracket (8) proceed to the next step. If rear engine mounting bracket does not have location for installing reverse switch bracket replace the rear engine mounting bracket with new rear engine mounting bracket (22). (Fig. 1)

Remove existing rear engine mounting bracket and replace with new rear engine mounting bracket (22) if existing bracket does not have location to install reverse switch bracket (8).

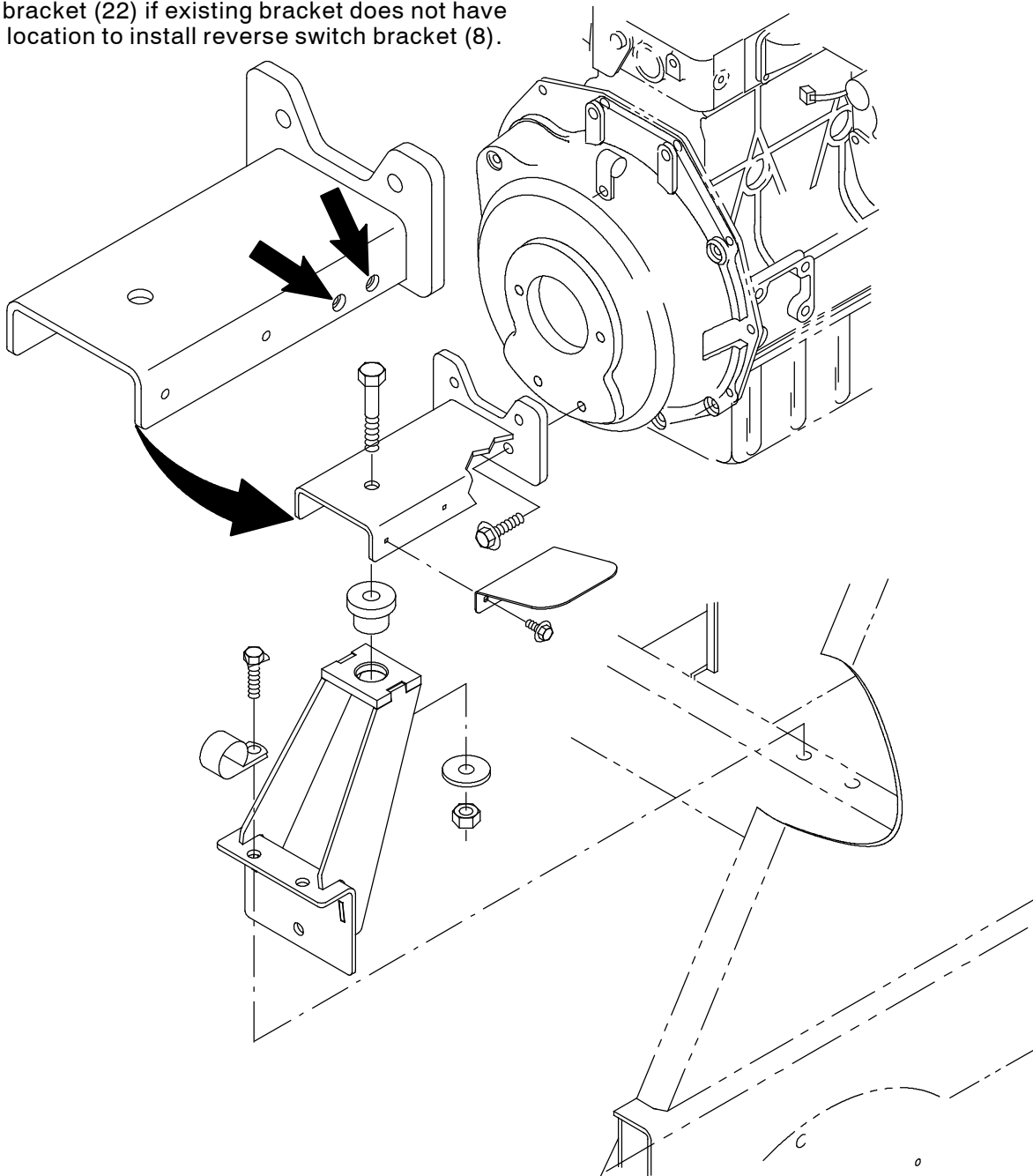


FIG. 1

4. Check the propel cable mounting bracket on the hydraulic pump. If propel cable mounting bracket has a tab located on bottom of bracket proceed to the *INSTALLATION* section. If the propel cable mounting bracket does not have tab located on the bottom of bracket, replace existing propel cable mounting bracket with new propel cable mounting bracket (23). (Fig. 2)

5. If the propel cable mounting bracket was replaced, adjust the new propel cable mounting bracket (23) so the machine does not move instantly upon start up, before the directional pedal is used to move the machine.

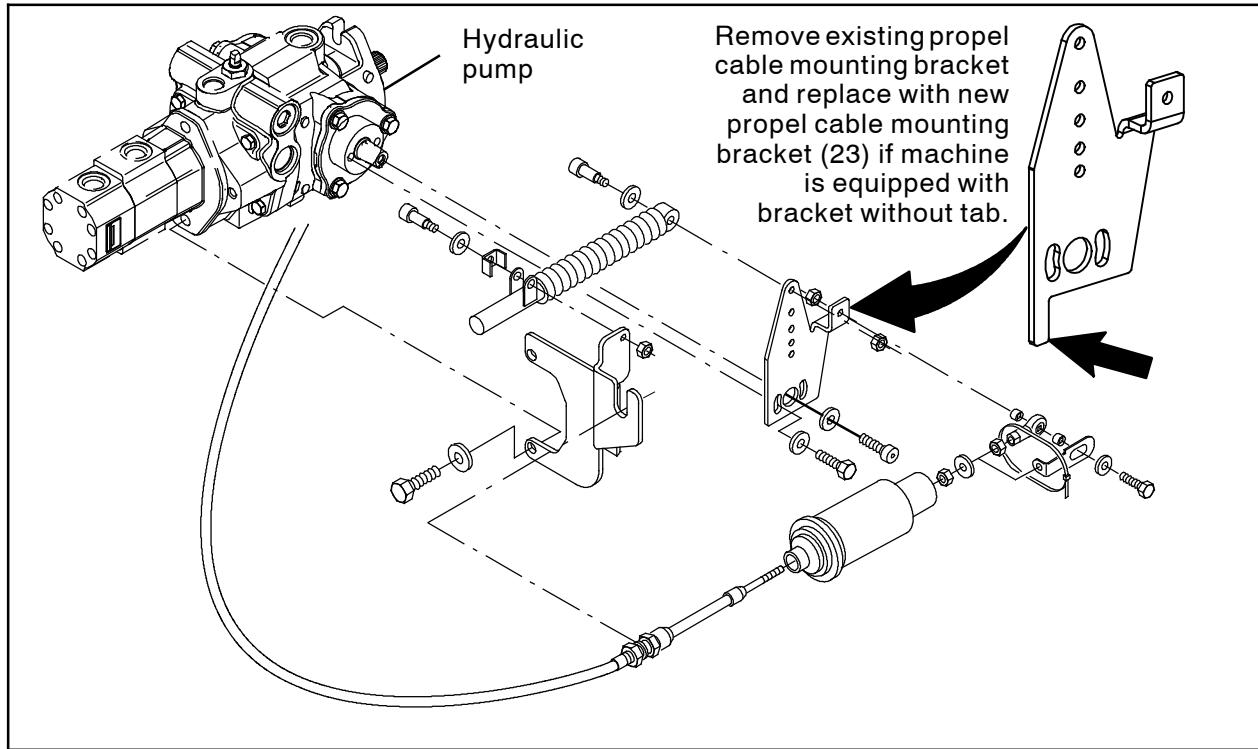
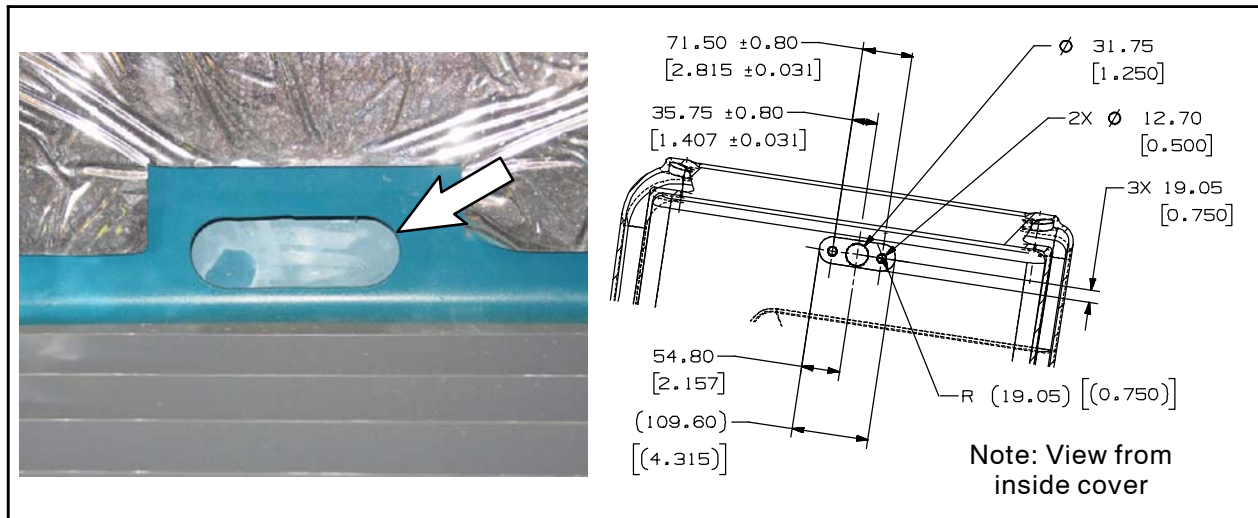


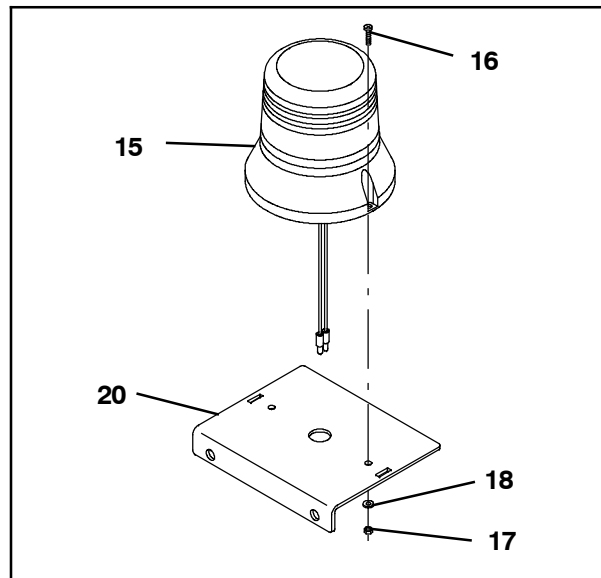
FIG. 2

**INSTALLATION:**



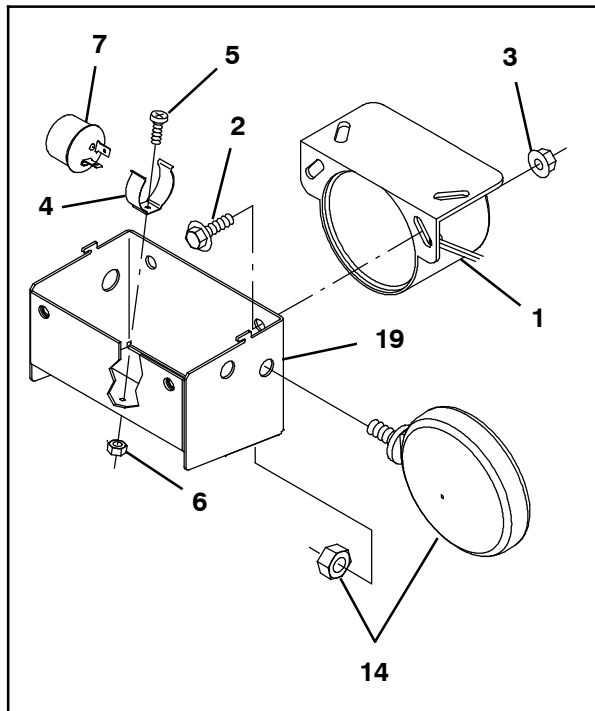
**FIG. 3**

1. Drill a 0.25" pilot hole into the center of the slot in the main cover. (Fig. 3)
2. Use the 0.25" hole drilled in the previous step as a reference to measure locations for the 0.50" holes. (Fig. 3)
3. Use a hole saw to cut a 1.25" hole into the main cover. (Fig. 3)
4. Drill two 0.50" holes into the main cover. (Fig. 3)
5. Deburr the 1.25" and 0.50" holes. (Fig. 3)
6. Trim the strobe light (15) wires to a 6" length and crimp bullet terminals (21) onto the wires.
7. Route the strobe light (15) cable through the hole in the light mounting plate (20) and use two M5 pan screws (16), two flat washers (18), and two M5 hex nuts (17) to install the strobe light onto the light mounting plate. (Fig. 4)



**FIG. 4**

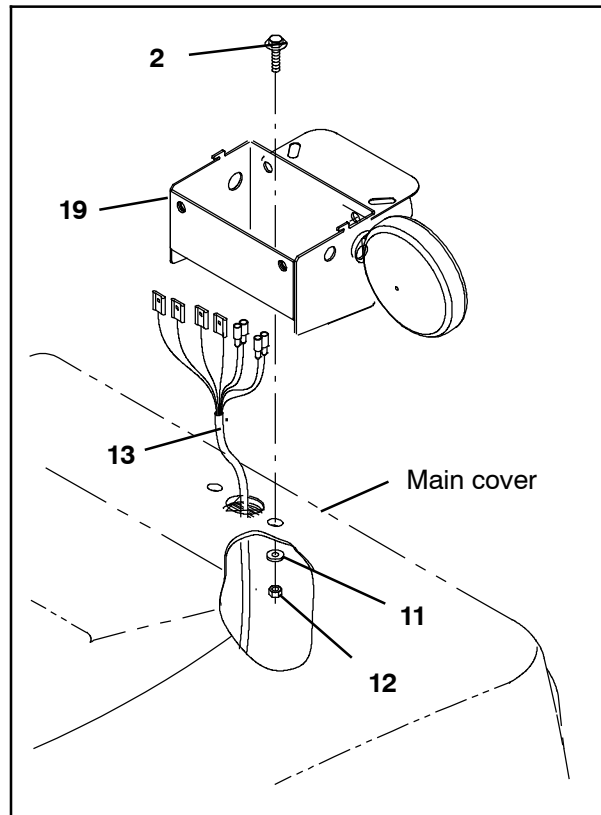
- Route the spot light (14) wires through the hole in the alarm bracket (19) and use the nut included with the spot light to install the spot light onto the alarm bracket. (Fig. 5)



**FIG. 5**

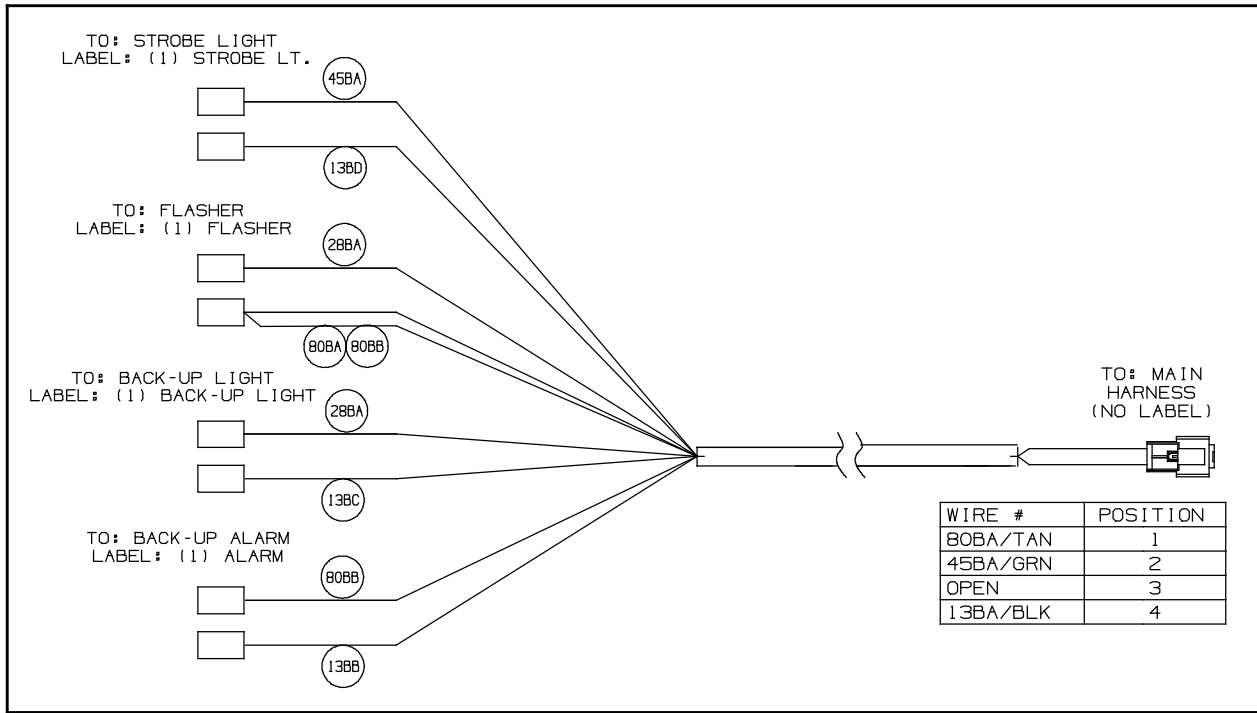
- Use two SEMS M8 hex screws (2) and two M8 flange hex nuts (3) to install the backup alarm (1) onto the alarm bracket (19). (Fig. 5)
- Route the backup alarm (1) wires through the hole in the alarm bracket (19) and into the interior of the alarm bracket. (Fig. 5)
- Use a M4 pan screw (5) and a M4 hex nut (6) to install the finger clip (4) inside the alarm bracket (19). (Fig. 5)

- Use two SEMS M8 hex screws (2), two flat washers (11), and two M8 hex nuts (12) to install the alarm bracket (19) onto the main cover. (Fig. 6)



**FIG. 6**

- Route the alarm / strobe harness (13) through the 1.25" hole in the main shroud and into the alarm bracket (19). (Fig. 3 / Fig. 5 / Fig. 6)
- Connect the alarm / strobe harness (13) to the 12VDC flasher (7) and inset the flasher into the finger clip (4) inside the alarm bracket (19). (Fig. 5 / Fig. 7)
- Connect the alarm / strobe harness (13) to the backup alarm (1) and spot light (14). (Fig. 5 / Fig. 7)



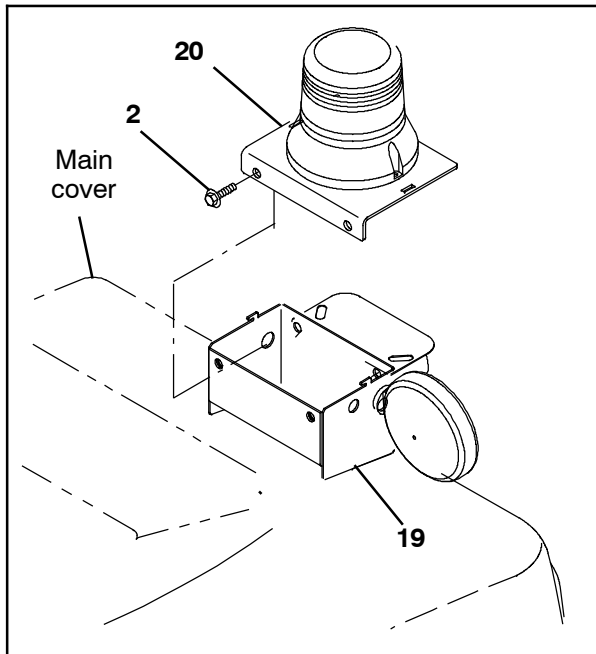
**FIG. 7**

16. Connect the alarm / strobe harness (13) to the strobe light (15) and use two SEMS M8 hex screws (2) to attach the light mounting plate (20) to the alarm bracket (19). (Fig. 7 / Fig. 8)

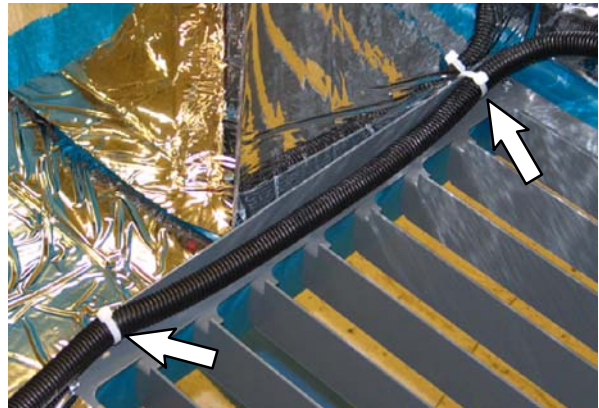
17. Connect the alarm / strobe harness (13) to the main wire harness. (Fig. 7 / Fig. 11)

18. Use two cable ties to secure the alarm / strobe harness (13) to the rear louvre panel on the main cover. (Fig. 9)

*NOTE: Do not pinch wires between the mounting plate (20) and alarm bracket (19) when assembling the mounting plate onto the alarm bracket.*

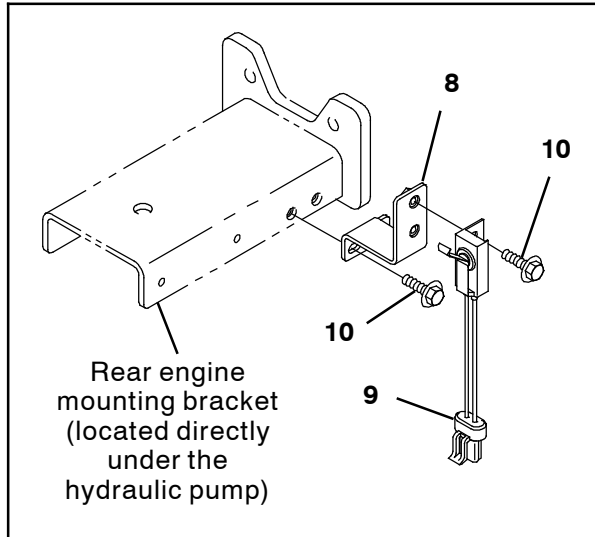


**FIG. 8**



**FIG. 9**

19. Connect the main wire harness to the switch (9). (Fig. 10 / Fig. 11)



**FIG. 10**

20. Wrap electrical tape around each electrical connection from the previous step. No metallic parts should touch the connections. Contact with other metallic parts could cause the system to short.
21. Use two SEMS M6 hex screws (10) to install the snap switch (9) onto the reverse switch bracket (8). (Fig. 10)
22. Use two SEMS M6 hex screws (10) to install the snap switch (9) / reverse switch bracket (8) onto the rear engine mounting bracket (located directly under the hydraulic pump). (Fig. 10)

23. Reconnect the battery cables to the batteries.

24. Start and test the machine. Use the headlight/ flashing light switch to turn on the strobe light. Operate the machine in reverse and to ensure the alarm / lights function. If necessary, adjust the position for the snap switch (9) and / or reverse switch bracket (8) if the lights and alarm do not operate when the machine is in reverse.

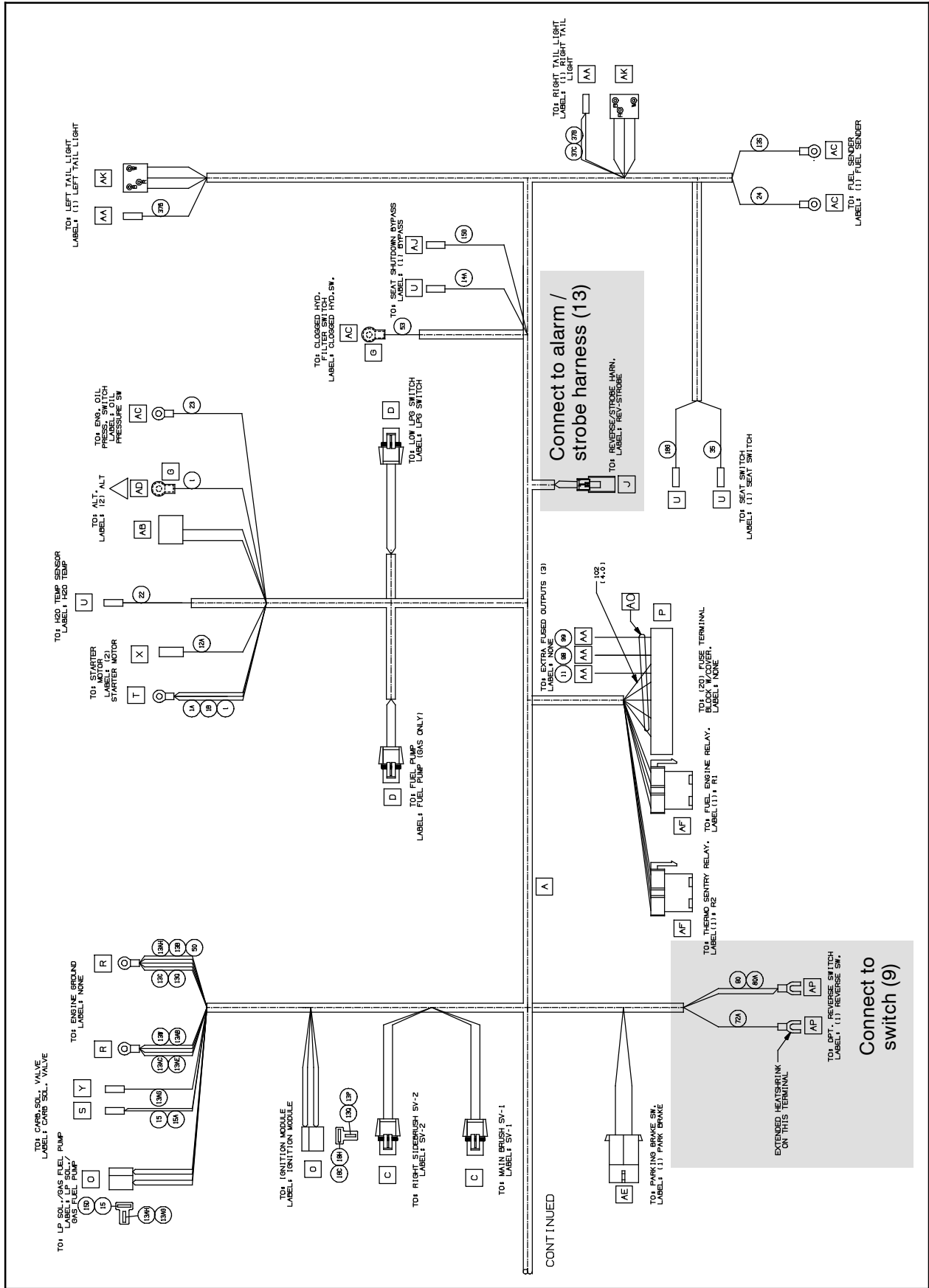


FIG. 11



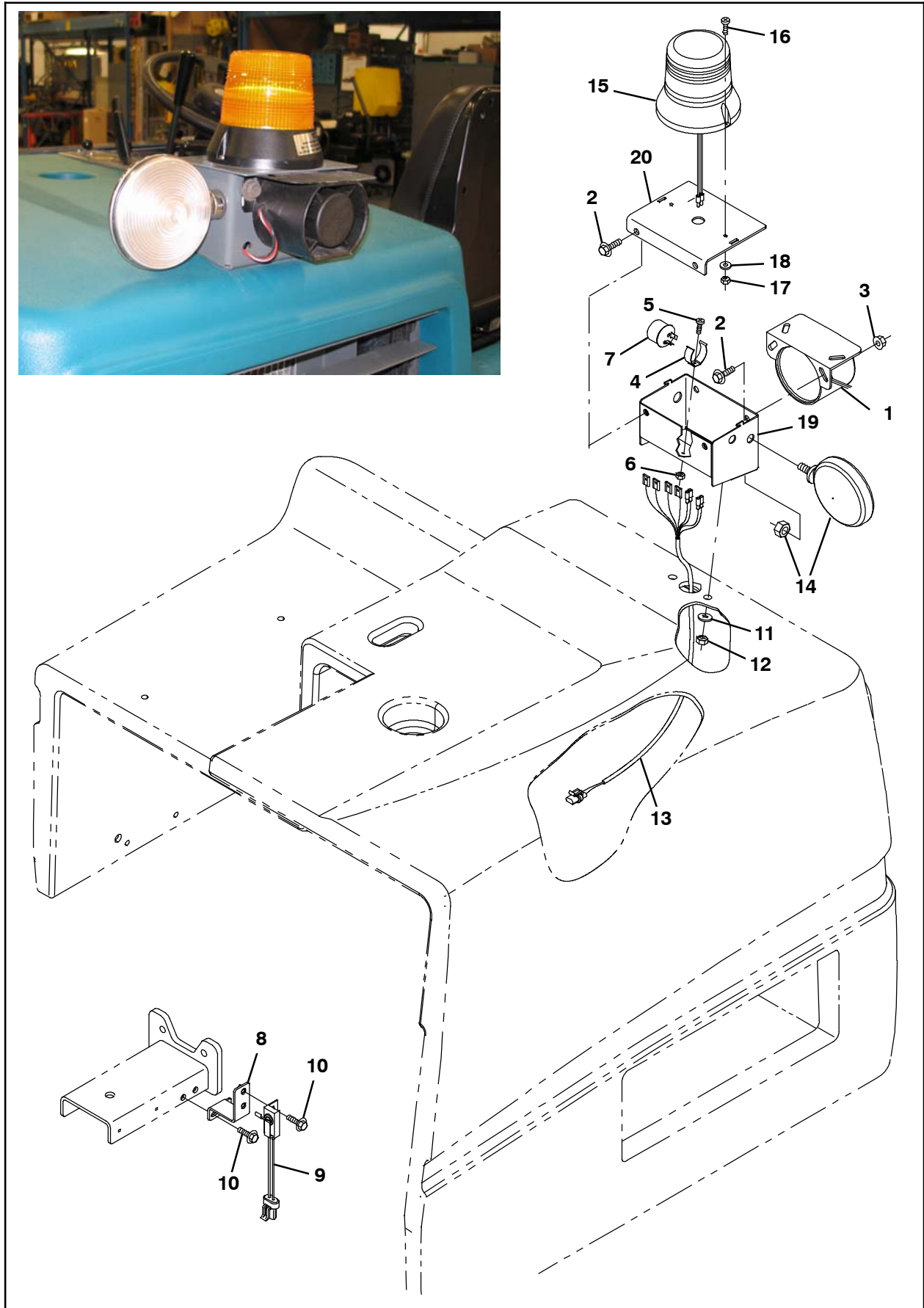


FIG. 12

**Bill of Materials for Alarm Kit, Backup, Strobe, Rear, IC, CI - 9007869**

Ref.	Tennant Part No.	Description	Qty.
▽	9007869	Alarm Kit, Backup, Strobe, Rear, IC, CI	1
▲	1 9007131	Alarm Assy, Backup, 12/48vdc	1
▲	2 1037346	Screw, Hex, M8 X 1.25 X 25, 9.8, SEMS	6
▲	3 07791	Nut, Hex, Flng, M8 X 1.25	2
▲	4 24576- 1	Clip, Grip, Finger, 1.19- 1.35d, Nk PI	1
▲	5 06927	Screw, Pan, Phl, M4 X 0.70 X 16, 4.8	1
▲	6 02850	Nut, Hex, Lock, M4 X 0.70, NI	1
▲	7 24576	Flasher, 12vdc [Hd552ps83]	1
▲	8 1067978	Bracket, Switch, Reverse	1
▲	9 1039735	Switch, Snap, 15a No	1
▲	10 1036892	Screw, Hex, M6 X 1.00 X 25, 9.8, SEMS	4
▲	11 32491	Washer, Flat, 0.31, Std	2
▲	12 08709	Nut, Hex, Lock, M8 X 1.25, NI	2
▲	13 1051788	Harness, Alarm / Strobe [S20]	1
▲	14 36438	Light, Spot, 12vdc, 21cp, Rwk 44025a	1
▲▽	15 1017250	Light, Strobe, Amb, 12- 48vdc	1
▲▲	9000845	Lamp, Bulb, Strobe	1
▲▲	9000879	Lens, Amb, F/ Revl / Flasher	1
▲	16 06933	Screw, Pan, Phl, M5 X 0.80 X 16, 4.8	2
▲	17 06549	Nut, Hex, Lock, M5 X 0.80, NI	2
▲	18 19066	Washer, Flat, 10	2
▲	19 1049554	Angle, Mtg, Alarm	1
▲	20 1049553	Plate, Mtg, Light	1
▲	21 55272	Terminal, Bullet, Mal, .157D, 12Ga	2
▲	22 1045645	Bracket Wldt, Mtg, Eng, Rear	1
▲	23 1046635	Bracket, Mtg, Cable, Propel	1

TENNANT COMPANY  
P. O. Box 1452  
Minneapolis, MN 55440-1452